

## 80457

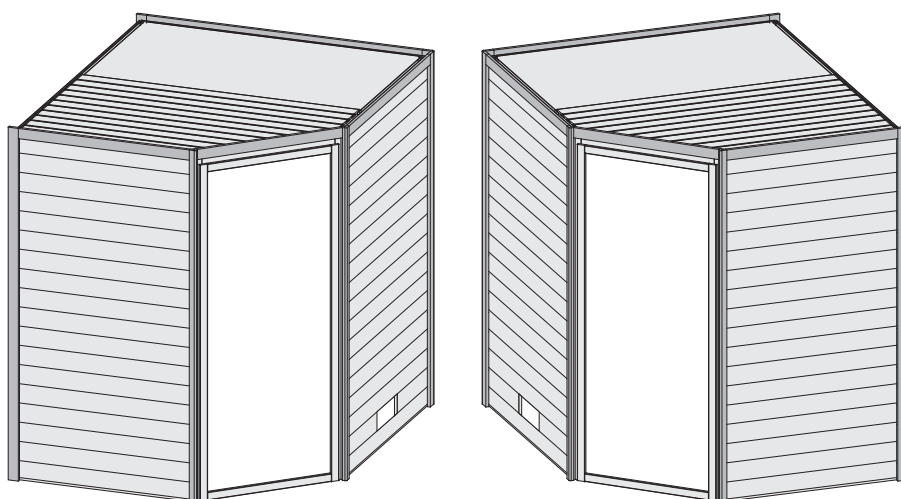

-  **Aufbauanleitung**
-  **Building Instructions**
-  **notice de montage**
-  **montagehandleiding**
-  **Montagevejledning**
-  **Instrucciones de construcción**
-  **Istruzioni per il montaggio**
-  **Montážní návod**

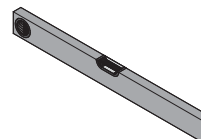

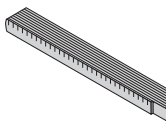
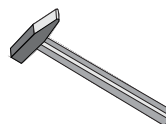
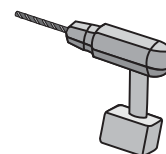

Vergleichen Sie zuerst die Material-liste mit Ihrem Paketinhalt! Bitte haben Sie Verständnis, dass Beanstandungen nur im nicht aufgebauten Zustand bearbeitet werden können!



Vergelijk eerst de lijst van materialen met de inhoud van uw pakket! Reclamaties kunnen alleen in behandeling worden genomen zolang de onderdelen nog niet zijn gemonteerd!



Confrontate questa distinta materiali prima con il contenuto del pacchetto! Vi preghiamo di comprendere che eventuali reclami possono essere accolti solo prima del montaggio!



First compare the list of materials with your package contents! Please understand that complaints can be processed in the non-built status only!



Start med at kontrollere materialelisten med indholdet af den leverede pakke! Vi gør venligst opmærksom på at reklamationer kun kan behandles for materialer som ikke er blevet bearbejdet!



Nejprve překontrolujte obsah balení podle materiálového listu! Mějte pochopení pro to, že případnou reklamaci se můžeme zabývat pouze tehdy, když díly nebudou smontované! Za pomoci tohoto seznamu můžete jednotlivé díly přiřadit k montážnímu návodu.





Commencez par comparer la liste du matériel avec le contenu de votre paquet! Sachez que nous traitons uniquement les réclamations concernant le matériel à l'état non monté!



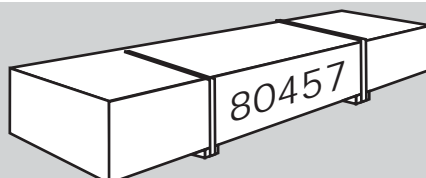

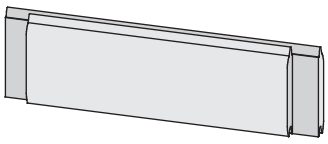
En primer lugar, compare la lista de material con el contenido del paquete. Rogamos entienda que las reclamaciones sólo pueden ser tramitadas antes de montar el objeto!

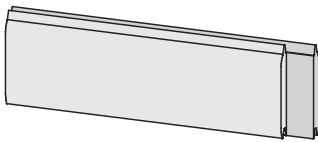

		
18 x A1	1021 x 121 x 38mm	ID 47601
17 x A2	1278 x 121 x 38mm	ID 21430
18 x A3	1628 x 121 x 38mm	ID 26150
17 x A4	1881 x 121 x 38mm	ID 21429

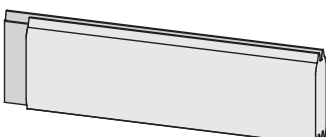
		
1 x A5	500 x 121 x 38mm	ID 25901

		
1 x A6	500 x 121 x 38mm	ID 25902

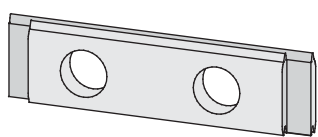
		
1 x A7	1881 x 121 x 38mm	ID 21864

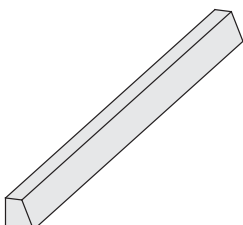
		
2 x C1	1916 x 36 x 36mm	ID 21814
2 x C2	1973 x 36 x 36mm	ID 21825

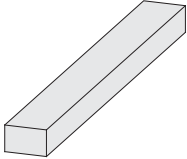
		
1 x B1	1920 x 20 x 3mm	ID 20799
2 x B2	1810 x 90 x 16mm	ID 71513
1 x B3	850 x 58 x 17mm	ID 48544
7 x B4	2000 x 58 x 17mm	ID 48541
2 x B5	800 x 45 x 18mm	ID 24796
1 x B6	880 x 45 x 18mm	ID 21440
1 x B7	954 x 45 x 18mm	ID 47602
1 x B8	1206 x 45 x 18mm	ID 21439
1 x B9	1556 x 45 x 18mm	ID 47603
1 x B10	1809 x 45 x 18mm	ID 21831
1 x B11	300 x 95 x 18mm	ID 19130
4 x B12	480 x 95 x 18mm	ID 20930
4 x B13	565 x 95 x 18mm	ID 15498
2 x B14	800 x 58 x 28mm	ID 15493
3 x B15	1916 x 36 x 36mm	ID 21431
1 x B16	781 x 78 x 38mm	ID 56718

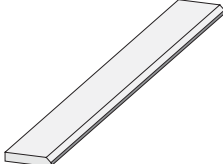
		
2 x F1	2000 x 58 x 17mm	ID 48545

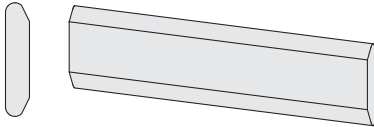
		
2 x F2	2100 x 40 x 18mm	ID 80276

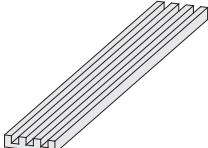
		
1 x E1	1820 x 140 x 26mm	ID 26480

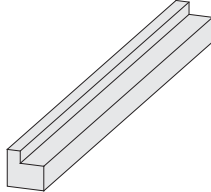
		
2 x E2	555 x 45 x 45mm	ID 40301
2 x E3	900 x 45 x 45mm	ID 47606

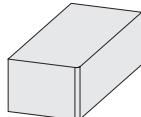
		
4 x K1	60 x 36 x 36mm	ID 5512

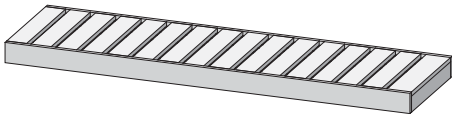
		
2 x L1	1810 x 550 x 90mm	ID 43994

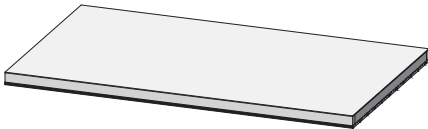
		
1 x M1	1582 x 918 x 57mm	ID 47604

		
1 x M2	1582 x 918 x 68mm	ID 73524



- Siehe Türpaket
- Opmerking Door Package
- Note Door Package
- Remarque Package porte
- Nota Paquete Puerta
- Nota Door Package
- Poznámka Door balíček

1 x D1

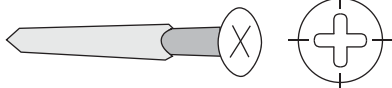

20 x	4 x 30mm	ID 3686
60 x	4 x 35mm	ID 3687
350 x	4 x 40mm	ID 21925
30 x	4 x 50mm	ID 3688
30 x	4 x 70mm	ID 3689
25 x	4,5 x 80mm	ID 9204
20 x	6 x 80mm	ID 47558
80 x	6 x 90mm	ID 26715

10m		ID 14025
-----	--	----------



60 x S1	4 x 30mm	ID 26116
6 x S2	12 x 18mm	ID 46403



6 x	3 x 16mm	ID 46376
-----	----------	----------

1 x		ID 50420
-----	--	----------

**Modell:**

**Brandgefahr!**  
Das Abheben von Gegenständen oder Textilien auf dem Saunenofen oder dessen Abstrahlungen ist verboten. Bei- und Entlüftungslüftungsdüsen dürfen nicht verschlossen werden.

**Anleitung beachten!**

<input type="checkbox"/> 3,6 kW	<input type="checkbox"/> 3kWPE - 230V	<input type="checkbox"/> Integrierte Steuerung	<input type="checkbox"/> Stoß
<input type="checkbox"/> 4,5 kW	<input type="checkbox"/> 3kWPE - 400V	<input type="checkbox"/> Externe Steuerung	<input type="checkbox"/> Fernsch.
<input type="checkbox"/> 9 kW			

Kaldu Holztechnik GmbH • Eduard-Sulzinger-Str. 11 • 38017 Braunschweig

1 x

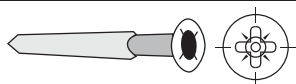

50 x	4,5 x 40mm	ID 26285
------	------------	----------

- Draufsicht
- Top view
- vue de dessus
- bovenaanzicht
- vista desde arriba
- vista desde arriba
- vista dall'alto
- púdorys

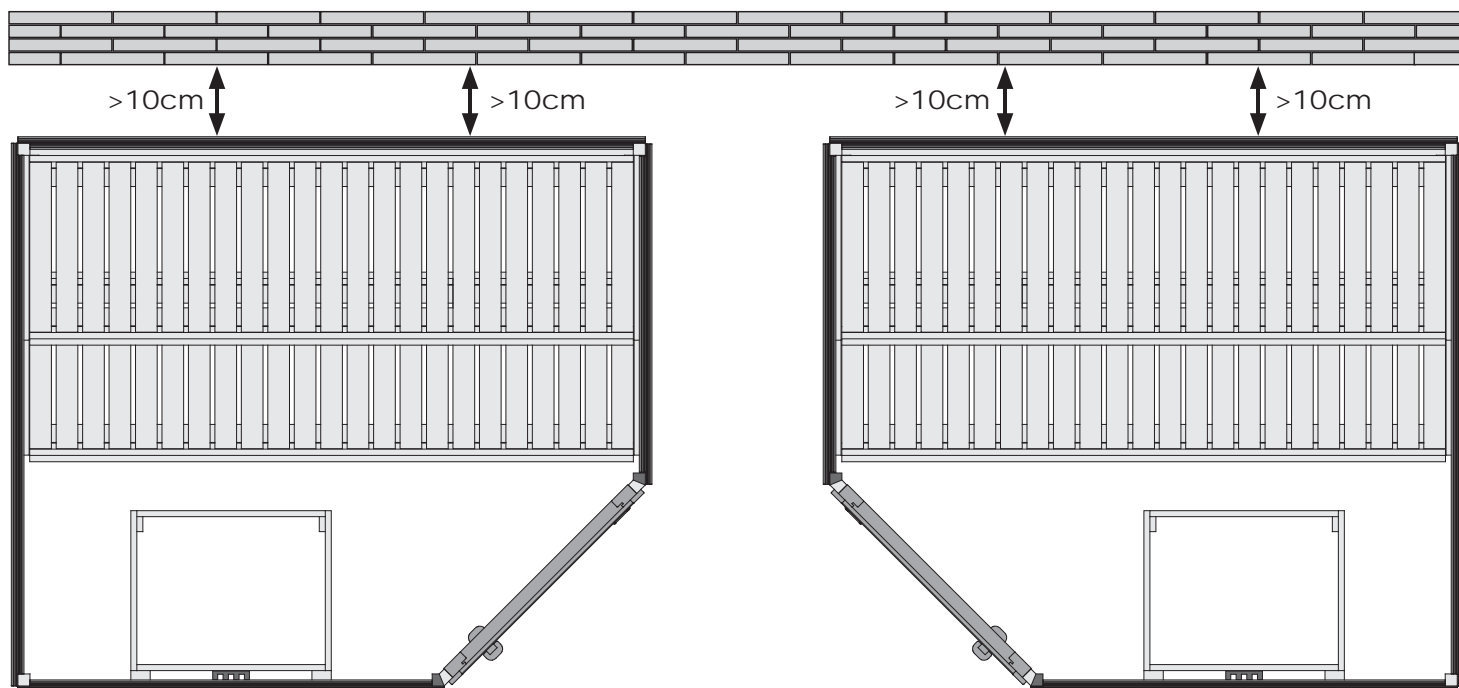

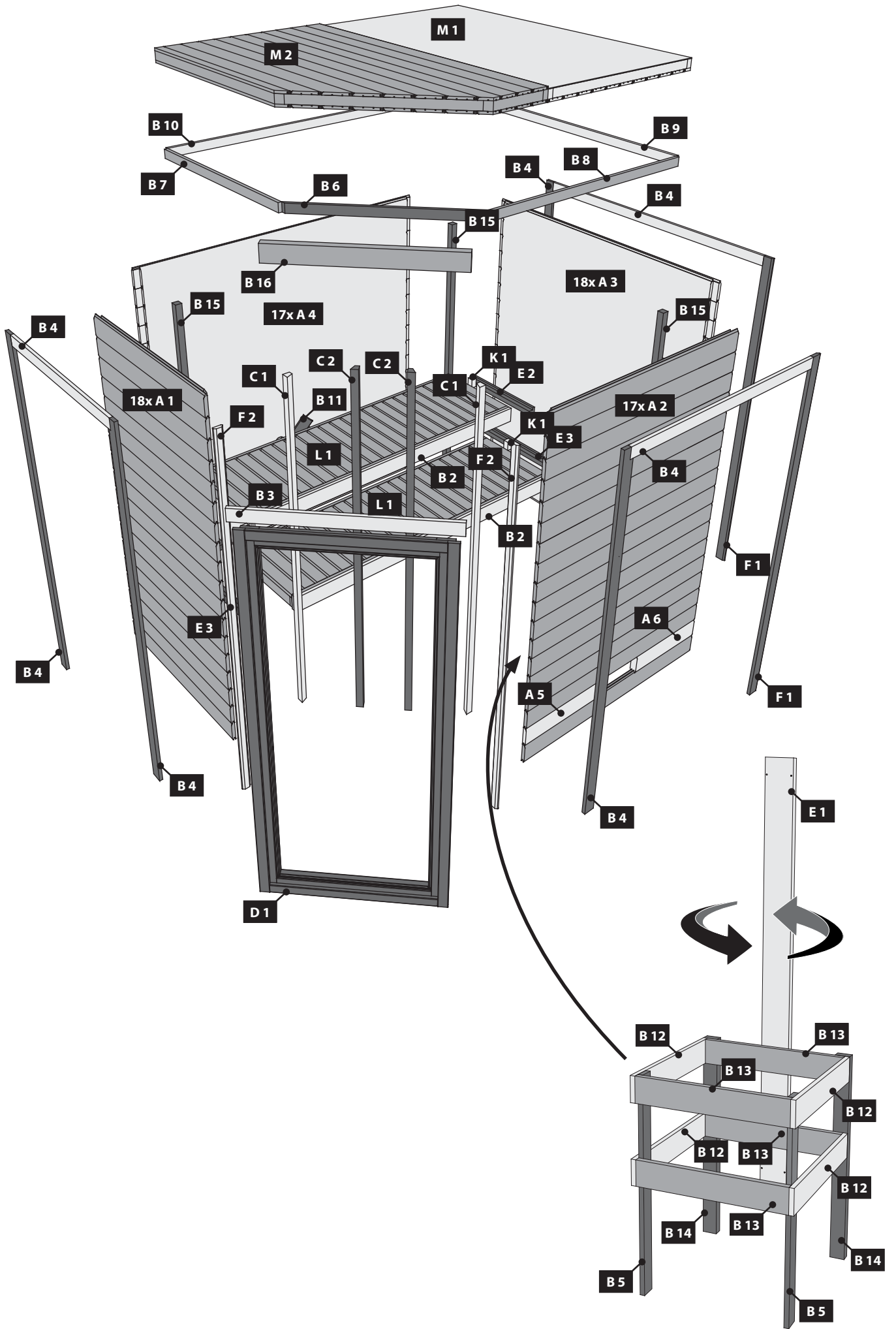

# 01

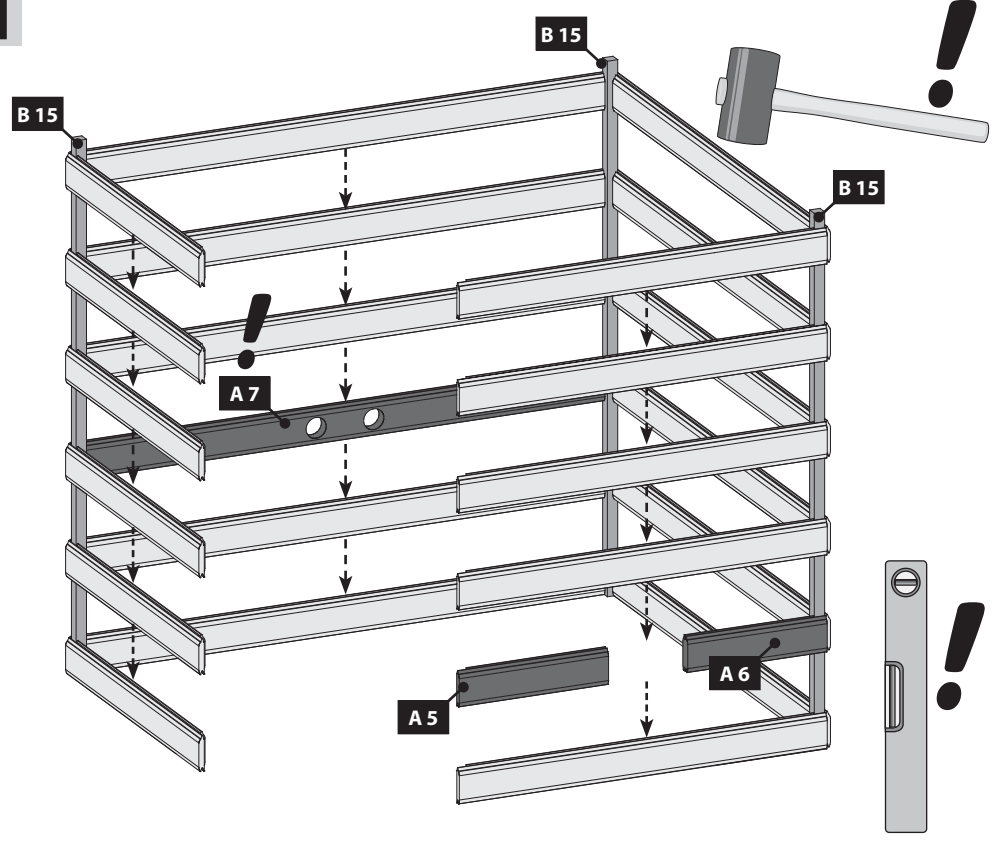

# 02.1

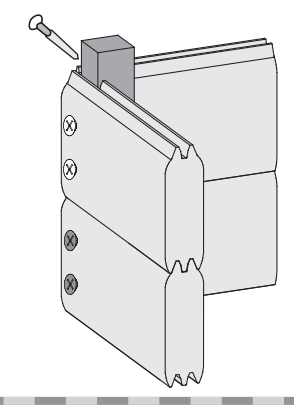



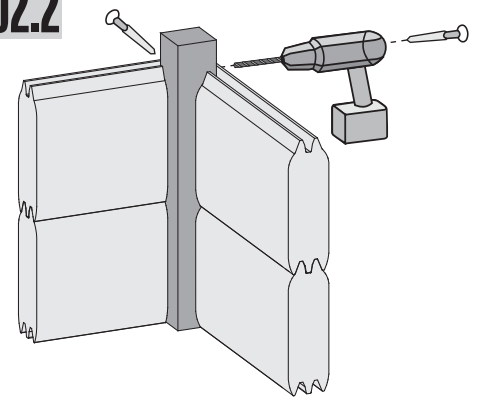

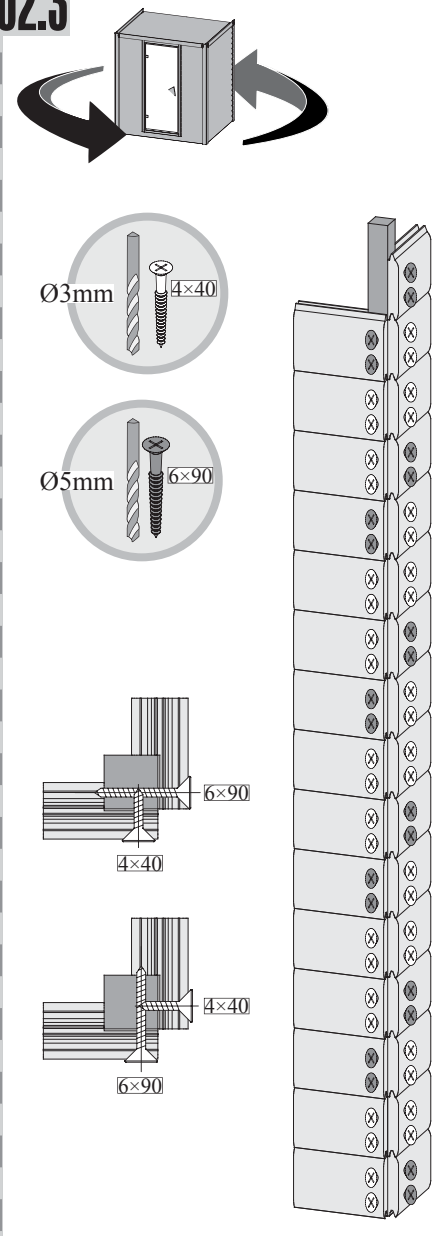

# 02.2



# 02.3



 Achten Sie auf die gleiche Höhe  
 Look for the same height  
 Faites attention à la même hauteur  
 Besteed aandacht aan de dezelfde hoogte

 Prestar atención a la misma altura  
 Prestare attenzione alla stessa altezza  
 Dávejte pozor na stejnou výšku

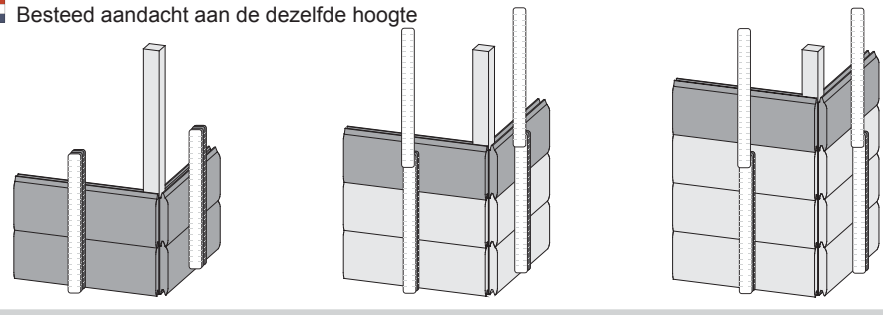

# 02

( 02.1 + 02.2 → 02.3 )

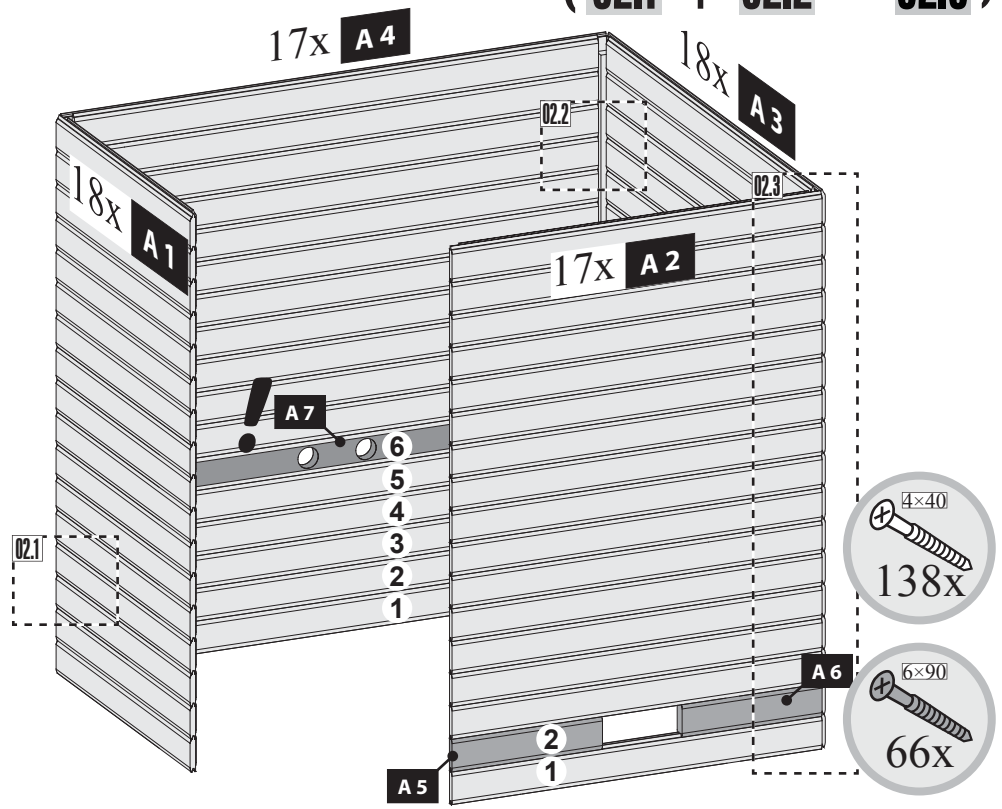

03

!!! A=B !!!

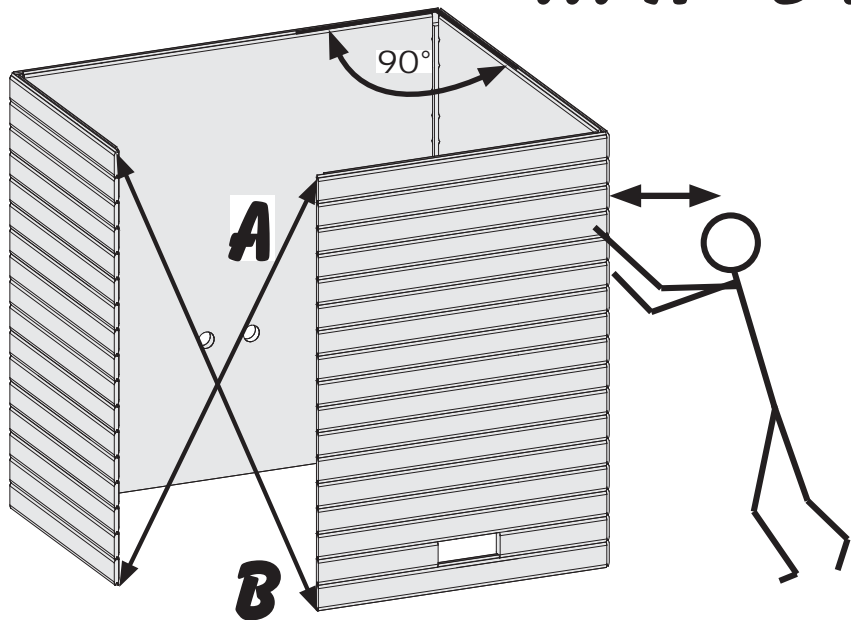

04.1

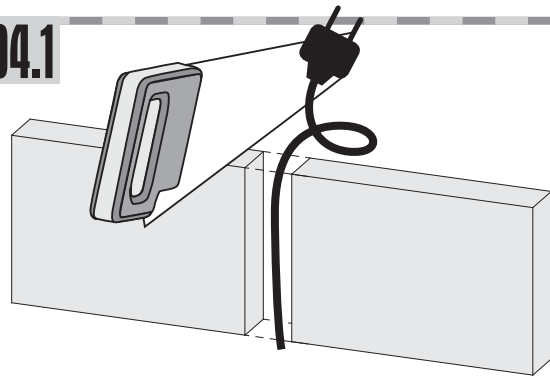

04

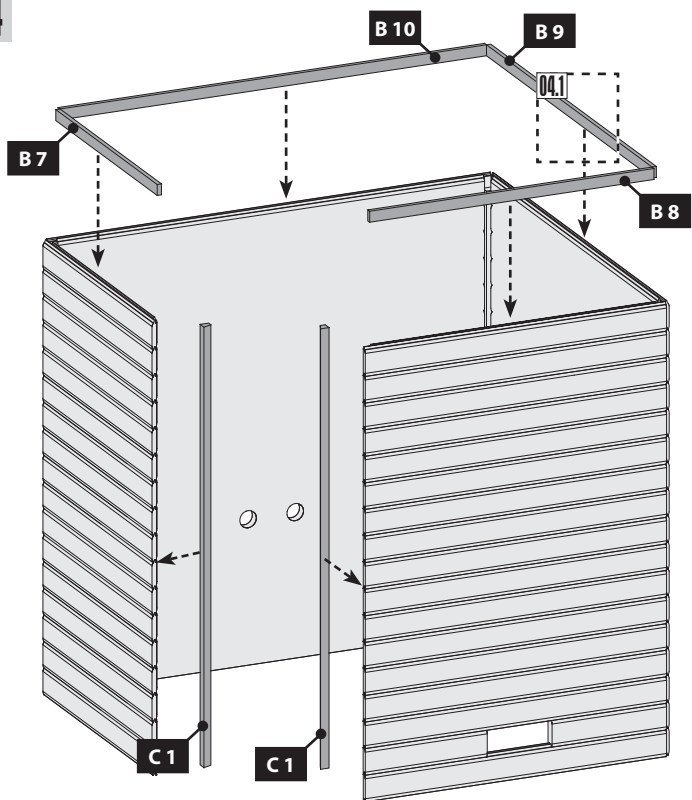

05

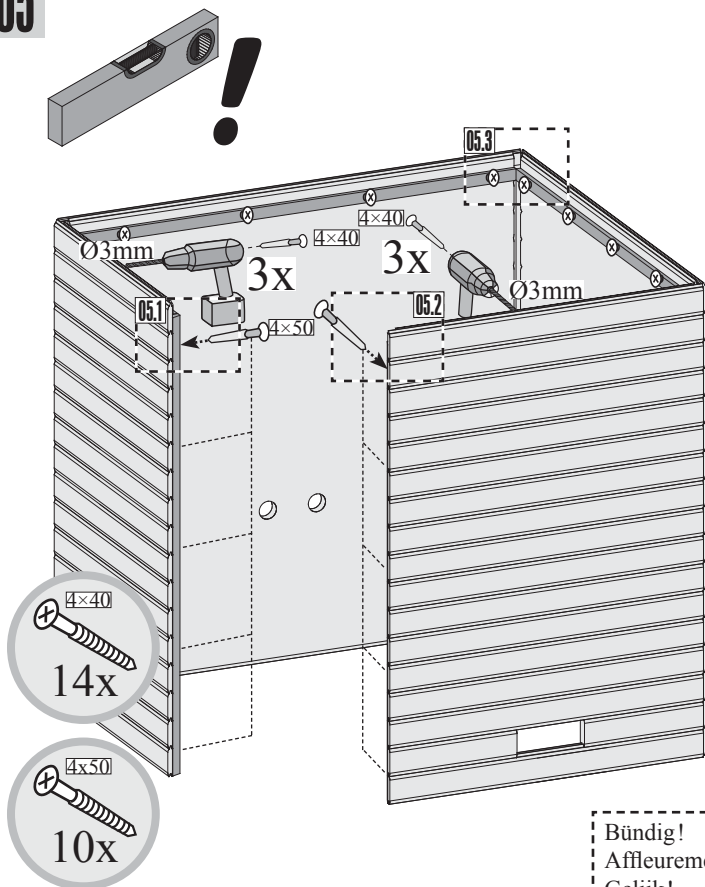

Bündig!  
Affleurement!  
Gelijk!  
Aras!  
Flush!  
Combacia!  
Stejný!

Bündig!  
Affleurement!  
Gelijk!  
Aras!  
Flush!  
Combacia!  
Stejný!

05.1

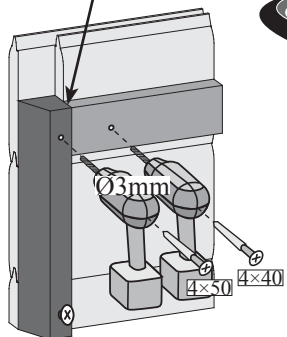

05.2

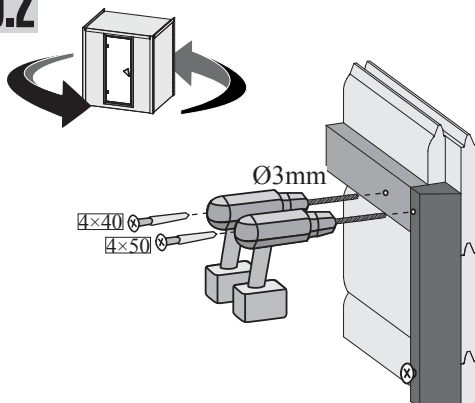

05.3

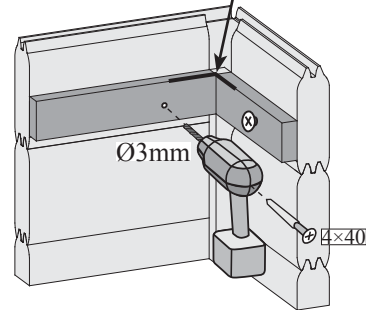



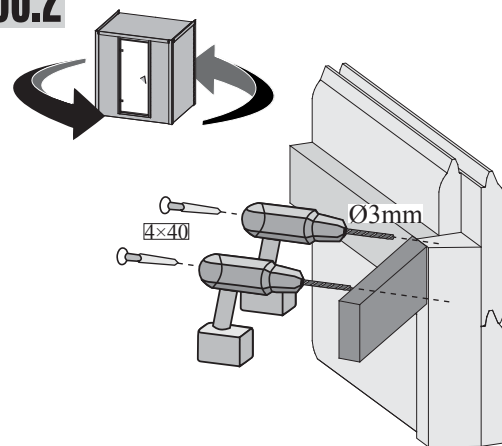
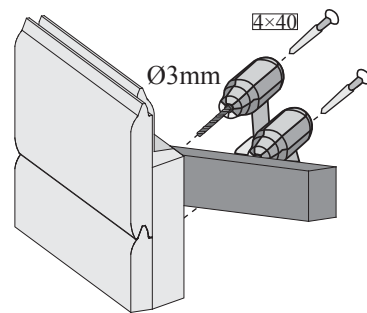
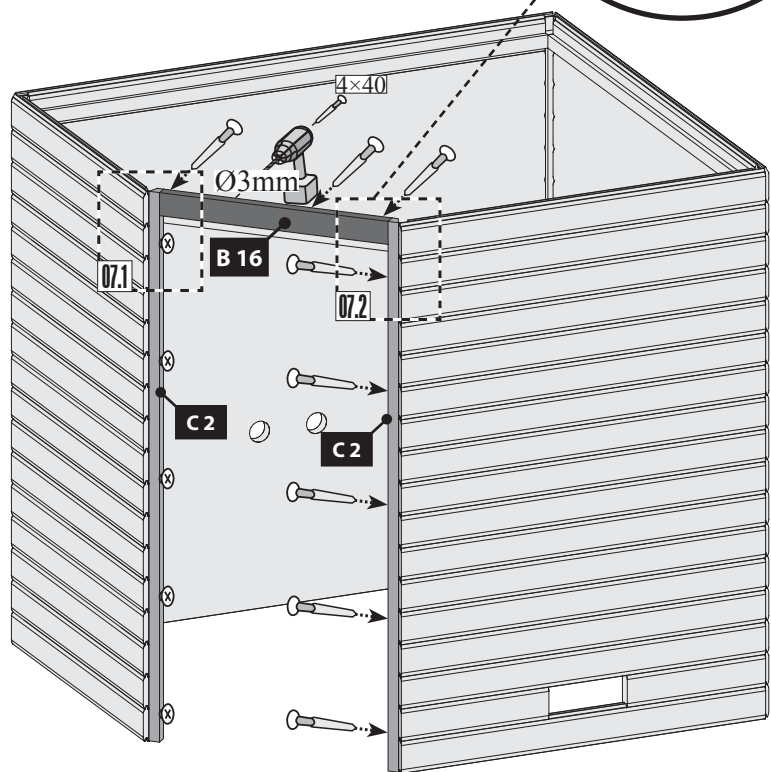
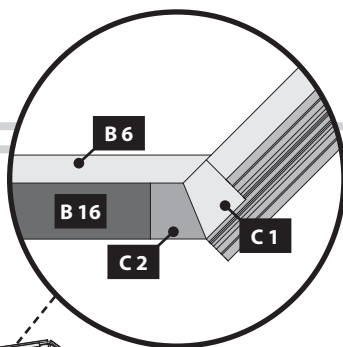
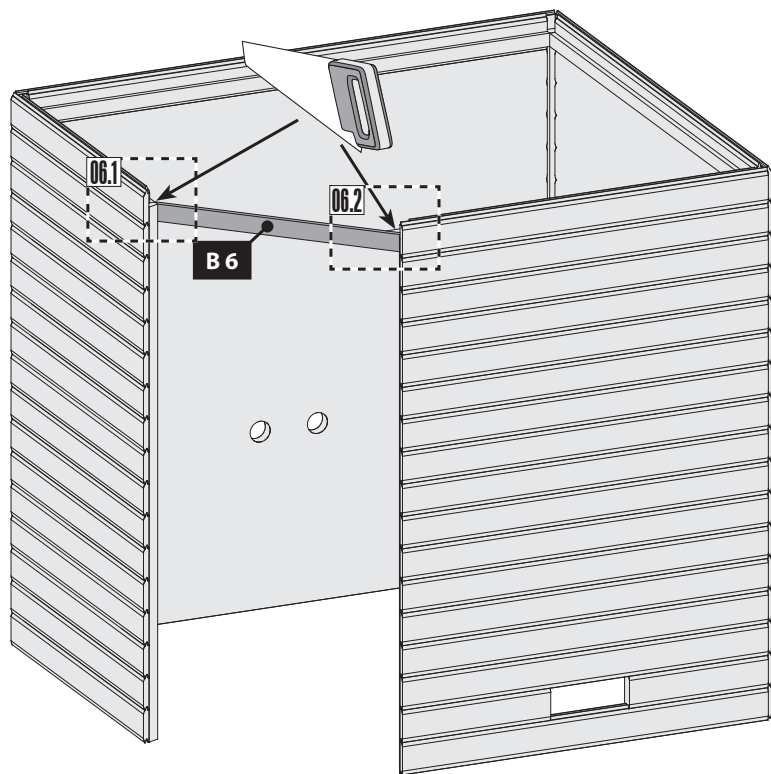

Bündig!  
Affleurement!  
Gelijk!  
Aras!  
Flush!  
Combacia!  
Stejný!

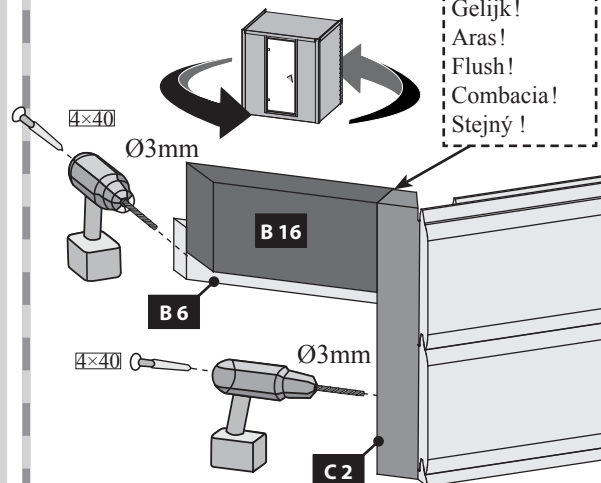
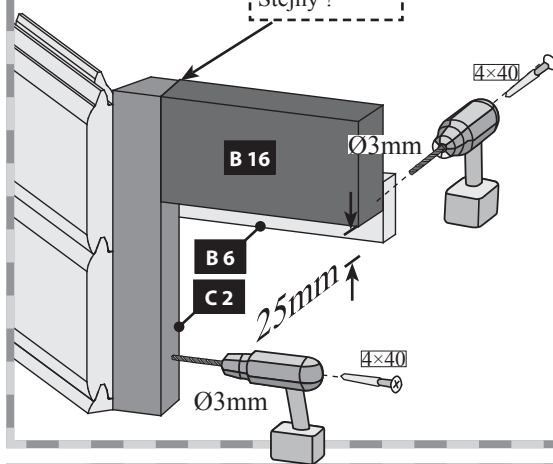

Bündig!  
Affleurement!  
Gelijk!  
Aras!  
Flush!  
Combacia!  
Stejný!



 Einbau Saunatür

 Sauna deur installatie

 Sauna Instalace dveře

 Installation de porte Sauna

 Instalación de la puerta Sauna

 Sauna door installation

 Installazione porta Sauna

**!!!** 01 → 03 **!!!**

08

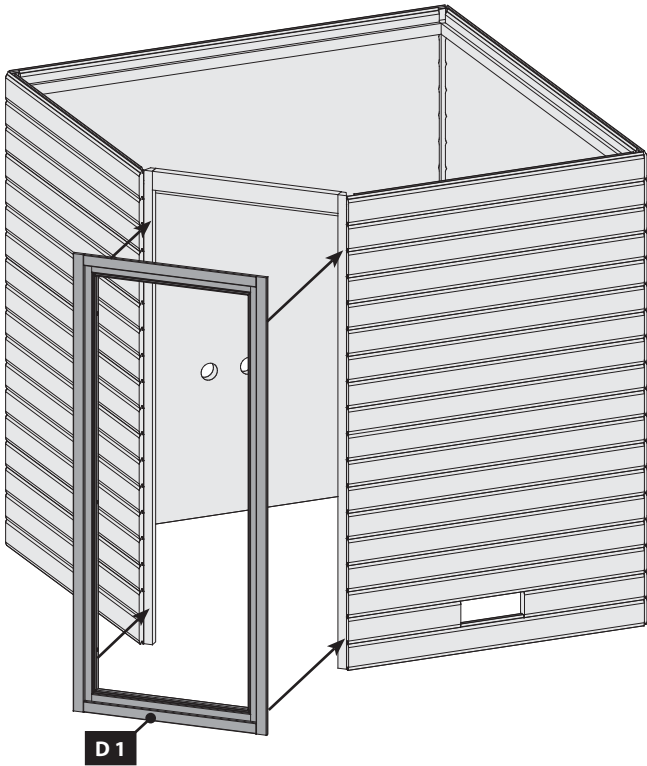

09

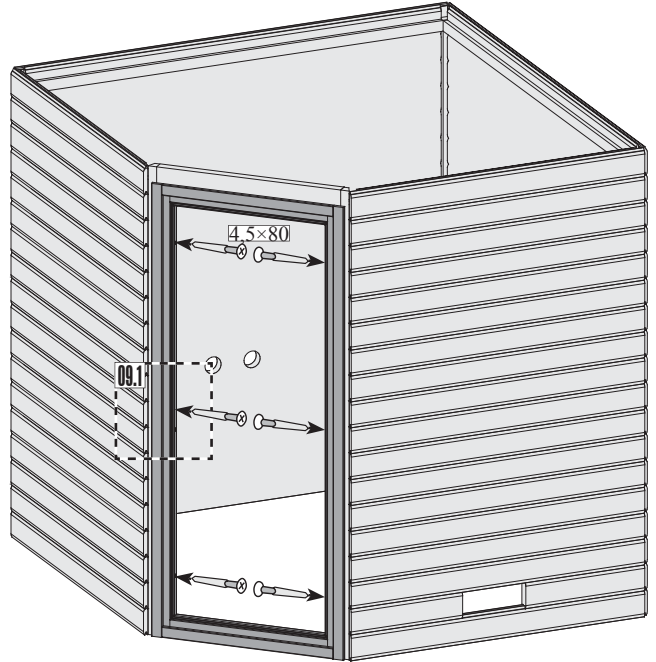

10

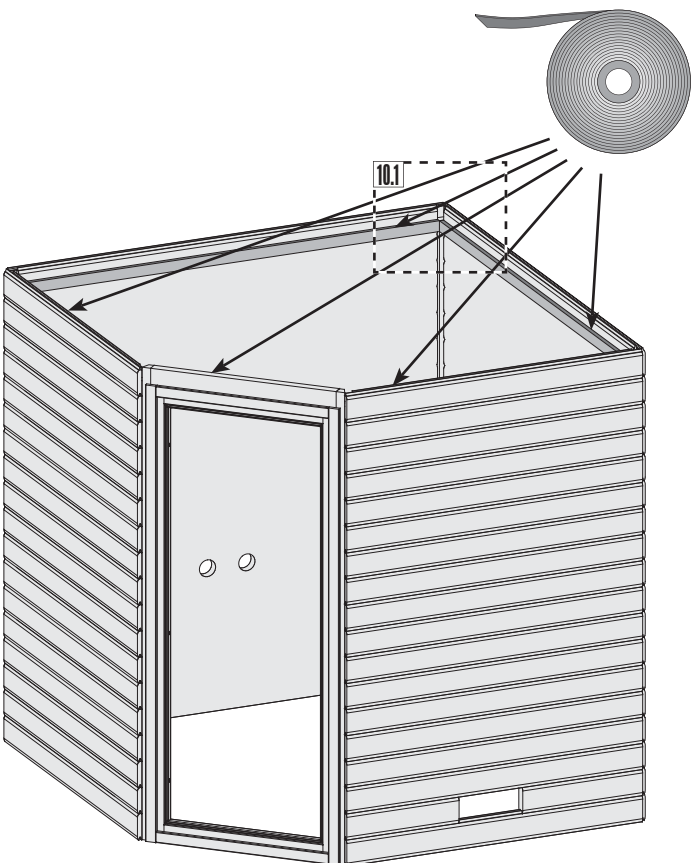

09.1-1

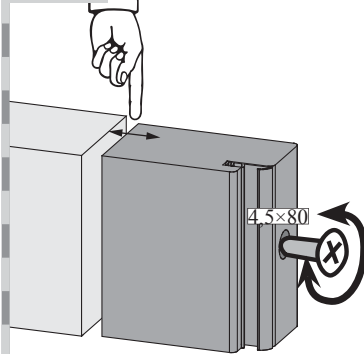

09.1-2

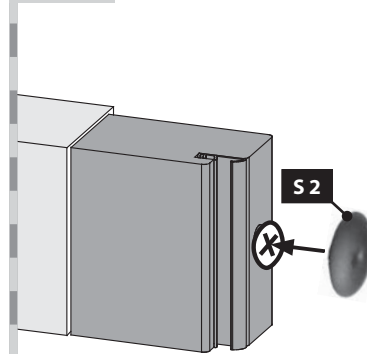

10.1

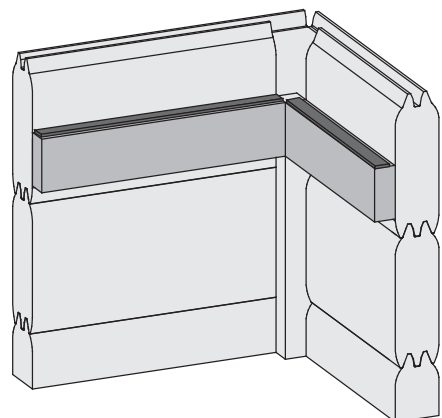



11

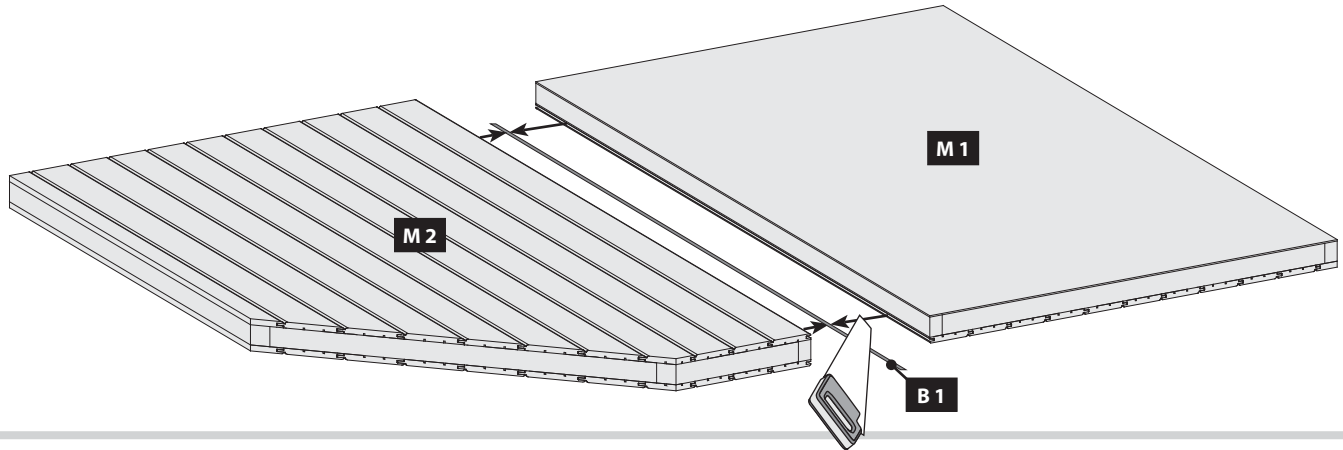

12

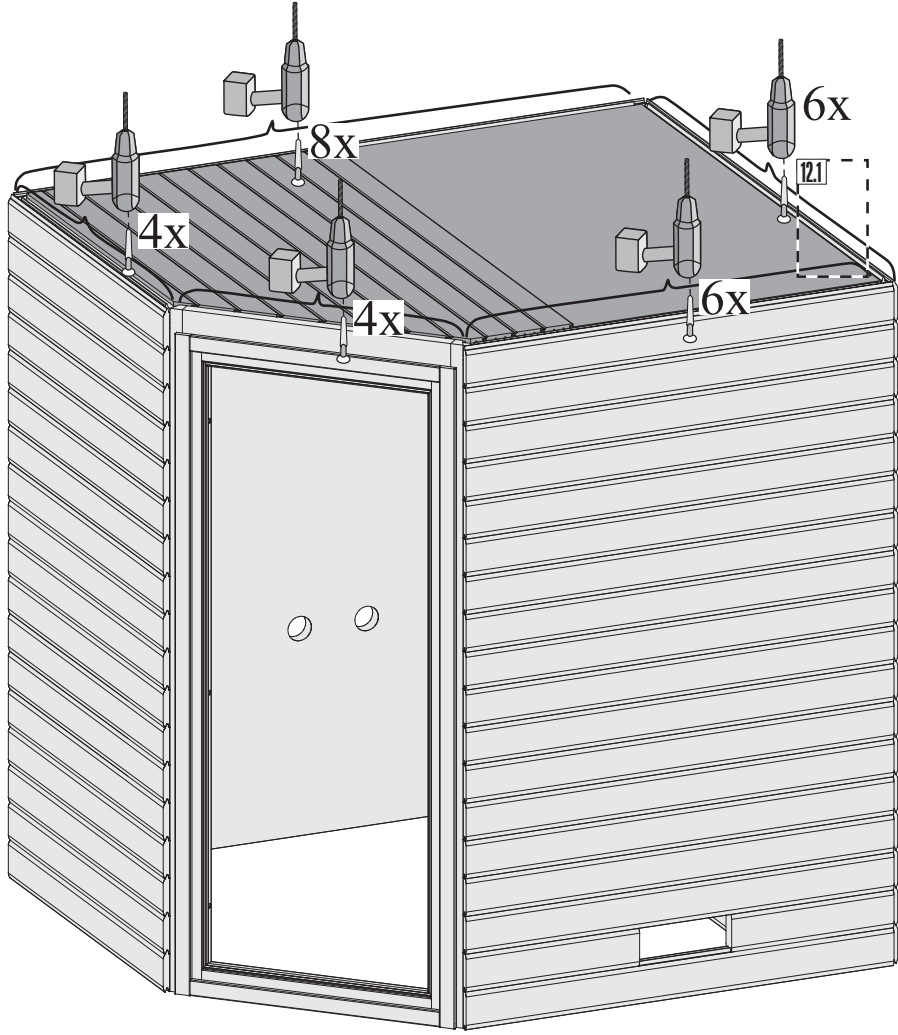

12.1

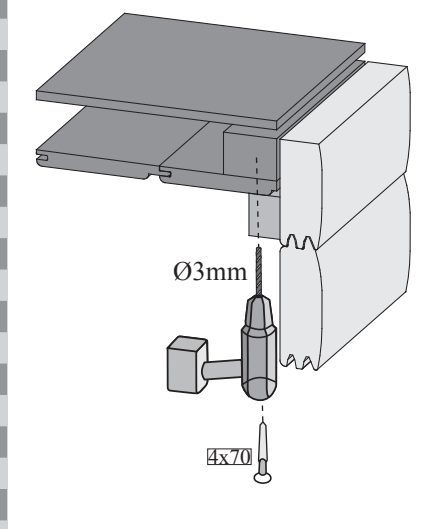

13

4x

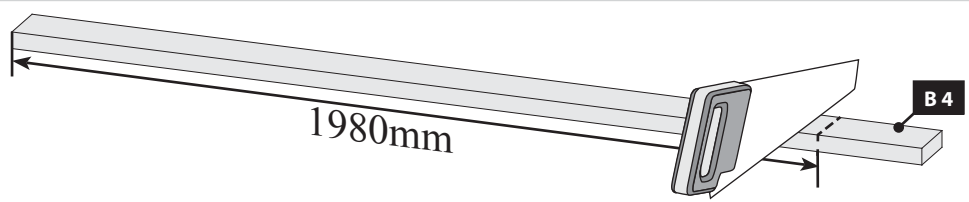

14

2x

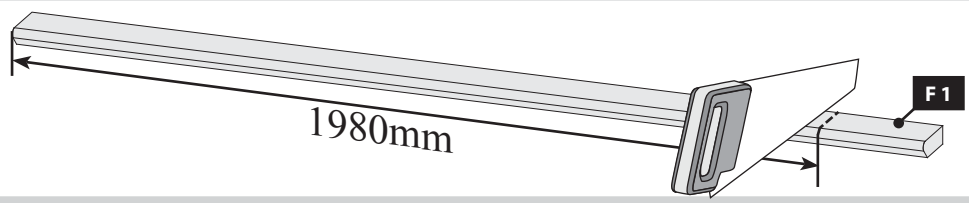

15

2x

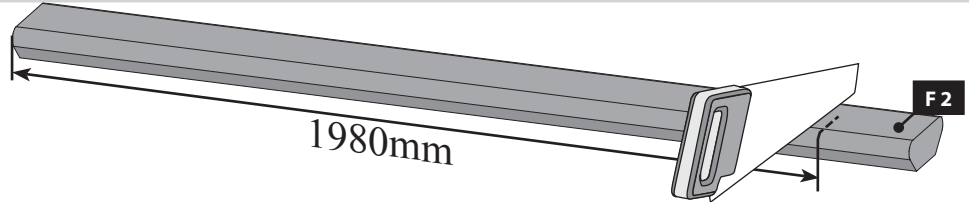



18 2x

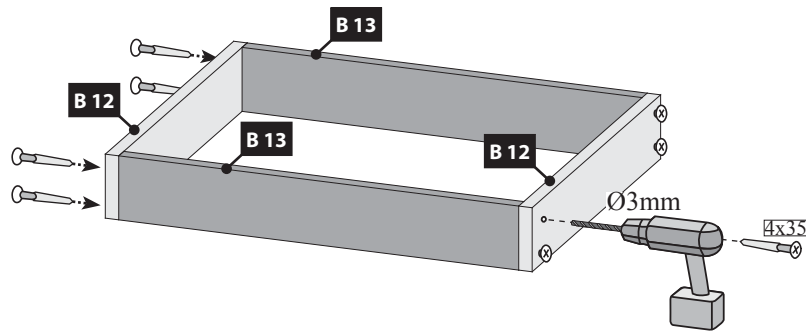

19 a

-  Nur bei 9 kW-Ofen
-  Seulement 9 kW chauffe
-  Only 9 kW heater
-  Slechts 9 kW heater
-  Sólo calentador de 9 kW
-  Solo riscaldamento 9 kW
-  Pouze topné těleso 9 kW

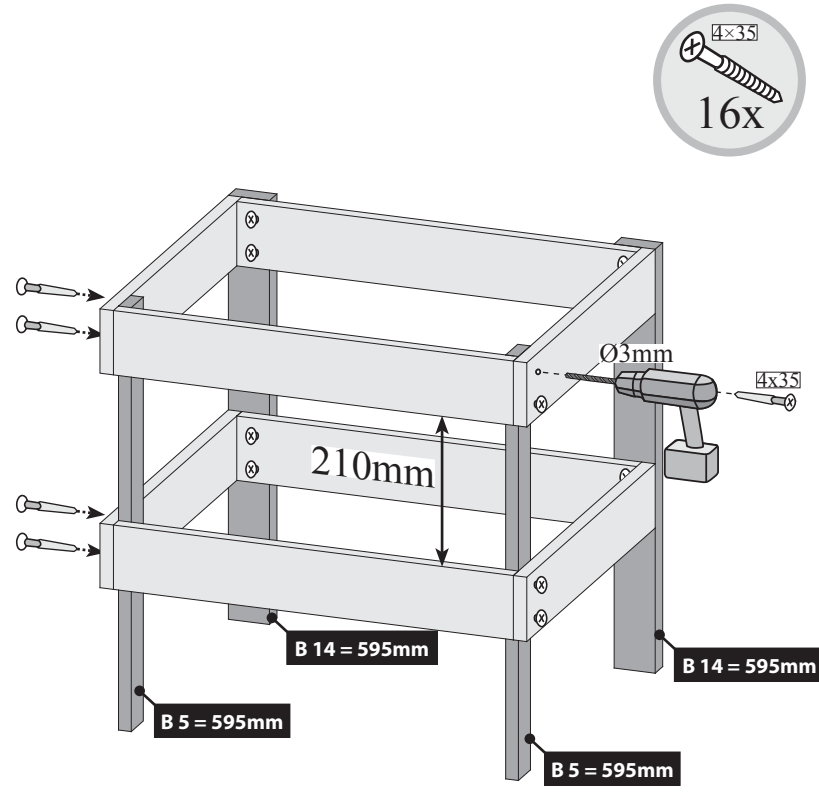
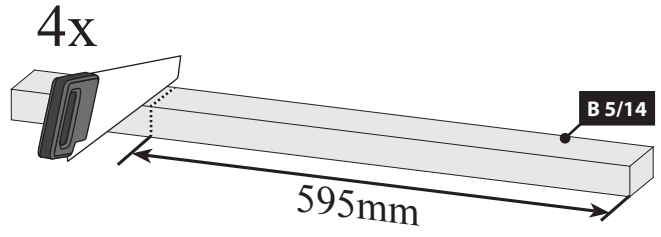

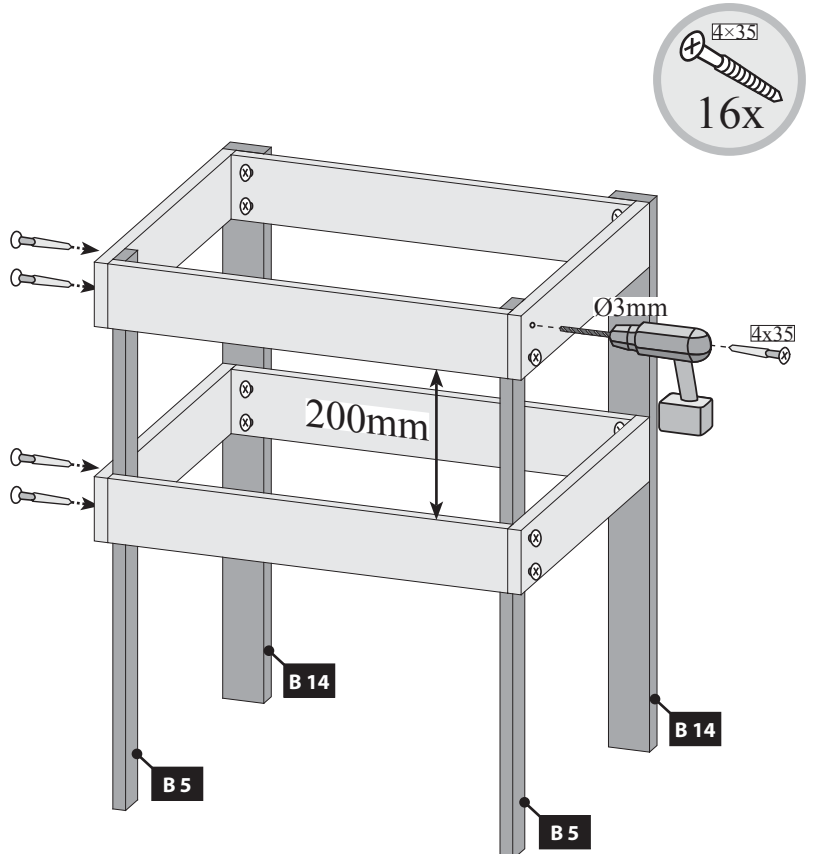

19 b

-  Bei allen anderen Öfen
-  Pour tous les autres fours
-  For all other furnaces
-  Voor alle andere ovens
-  Para todos los otros hornos
-  Per tutti gli altri tipi di forni
-  U všech ostatních pecích

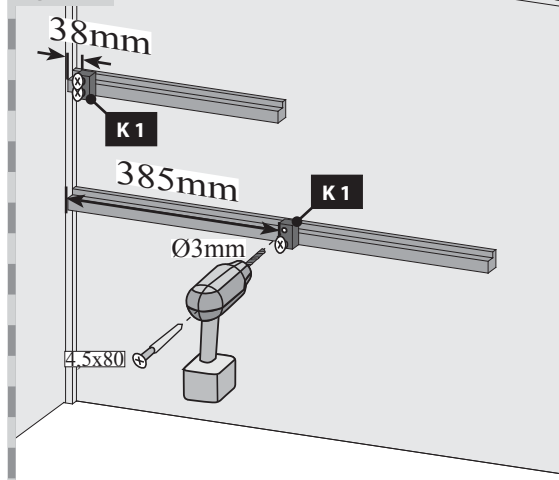
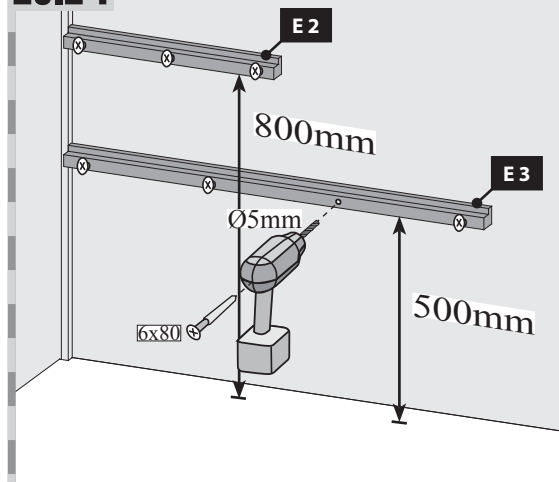
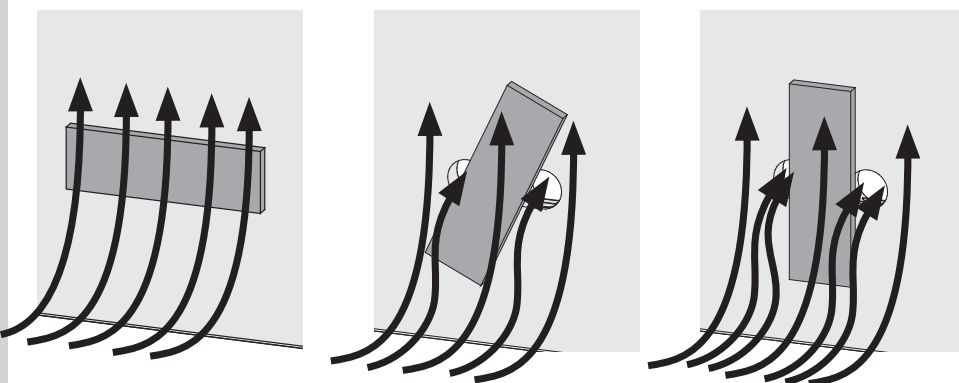
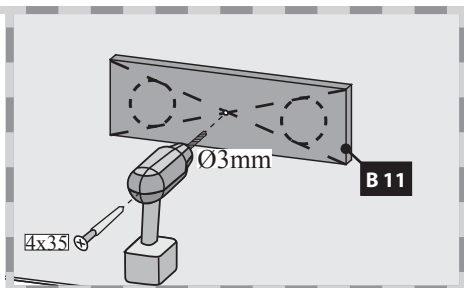
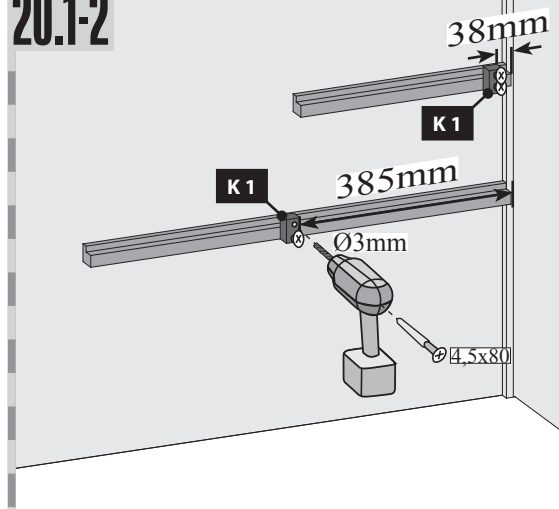
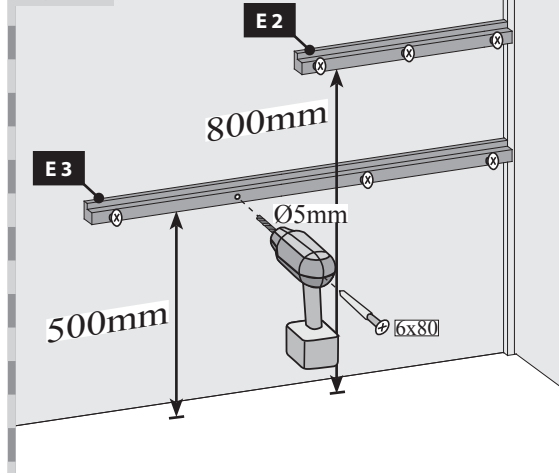
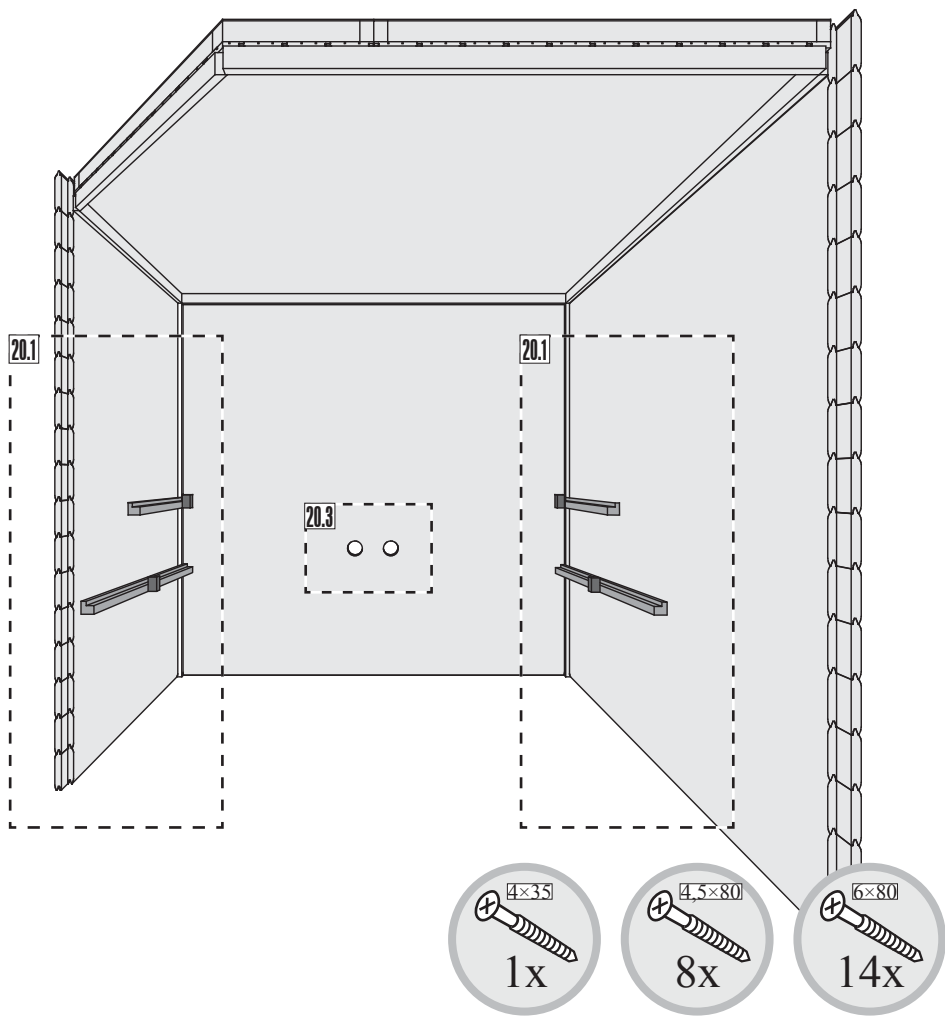





 Hier ist die Funktionsweise des Brettes abgebildet. Regeln Sie damit die Abluft nach Ihren eigenen Wünschen.

 Ceci représente le mode de fonctionnement de la planche. Avec elle, réglez l'écoulement de l'air selon vos désirs.

 This figure shows the functional principle of the board. Regulate the exhaust air according to your own wishes.

 Hier is de werking van het plankje afgebeeld. Regel daarmee de luchtafvoer naar eigen wens.

 Aquí está representada la forma de funcionamiento de la tabla. Regule con ello el aire de salida según sus propios deseos.

 Viene illustrato il principio di funzionamento della tavoletta di regolazione della ventilazione. Con essa si può regolare a piacere la ventilazione.

 Zde je zobrazená funkce desky. Regulujte s ní odsávací vzduch dle Vašeho přání.

21 2x

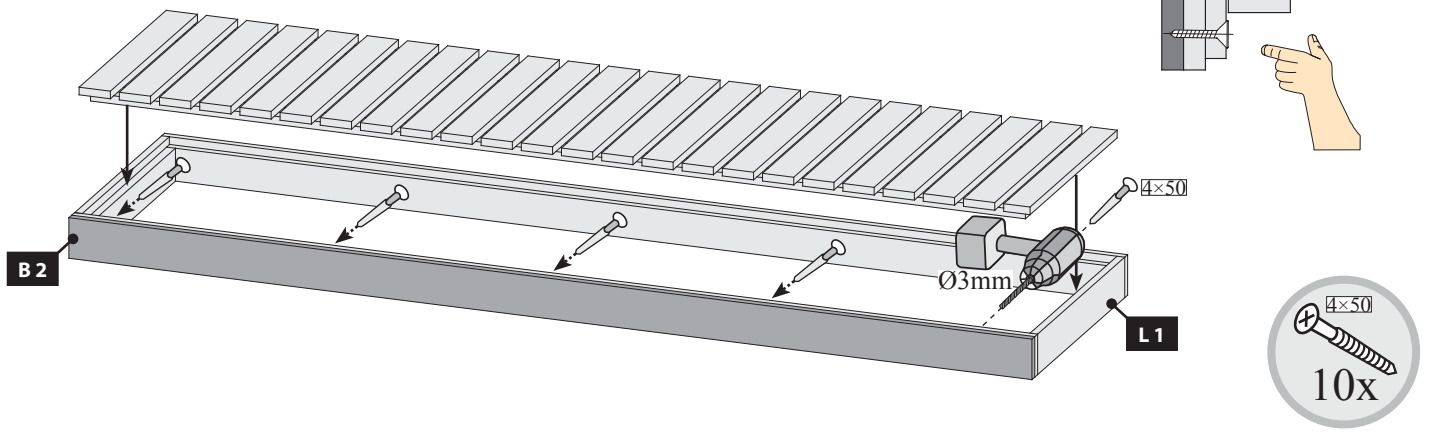

22

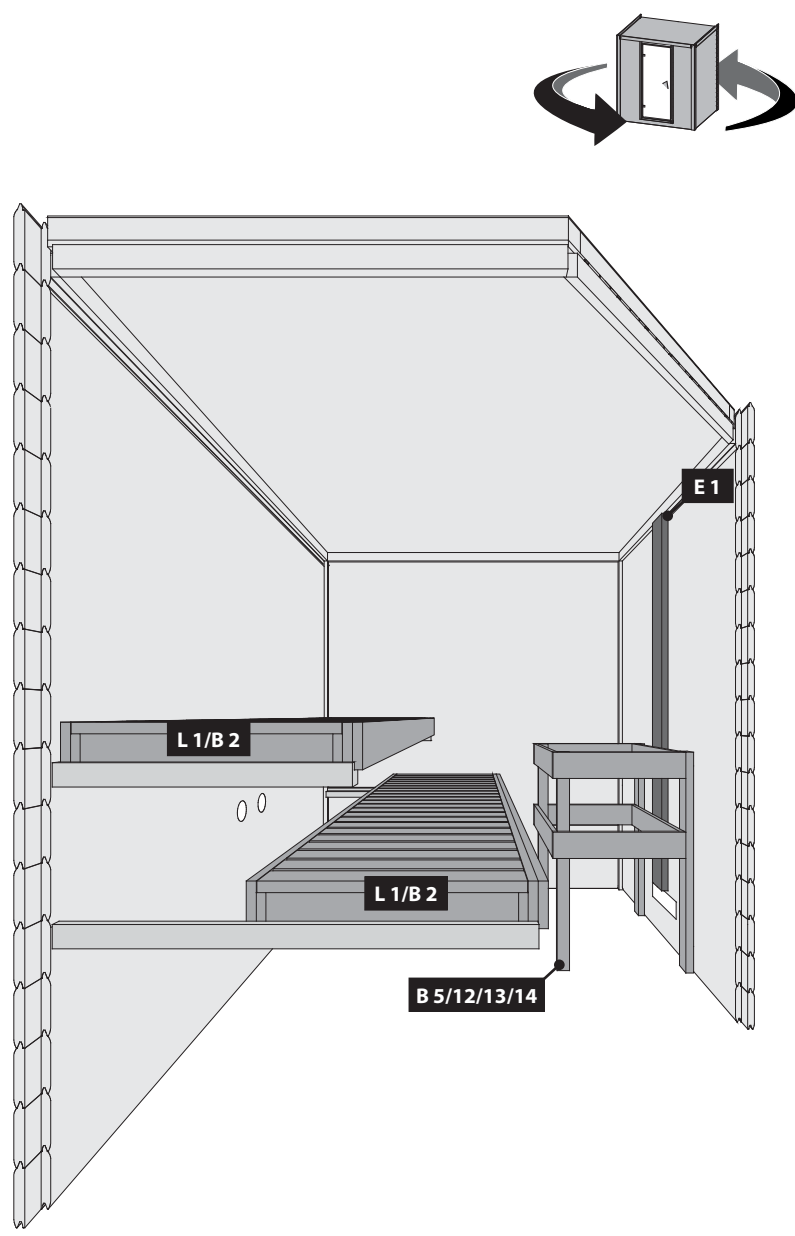

23

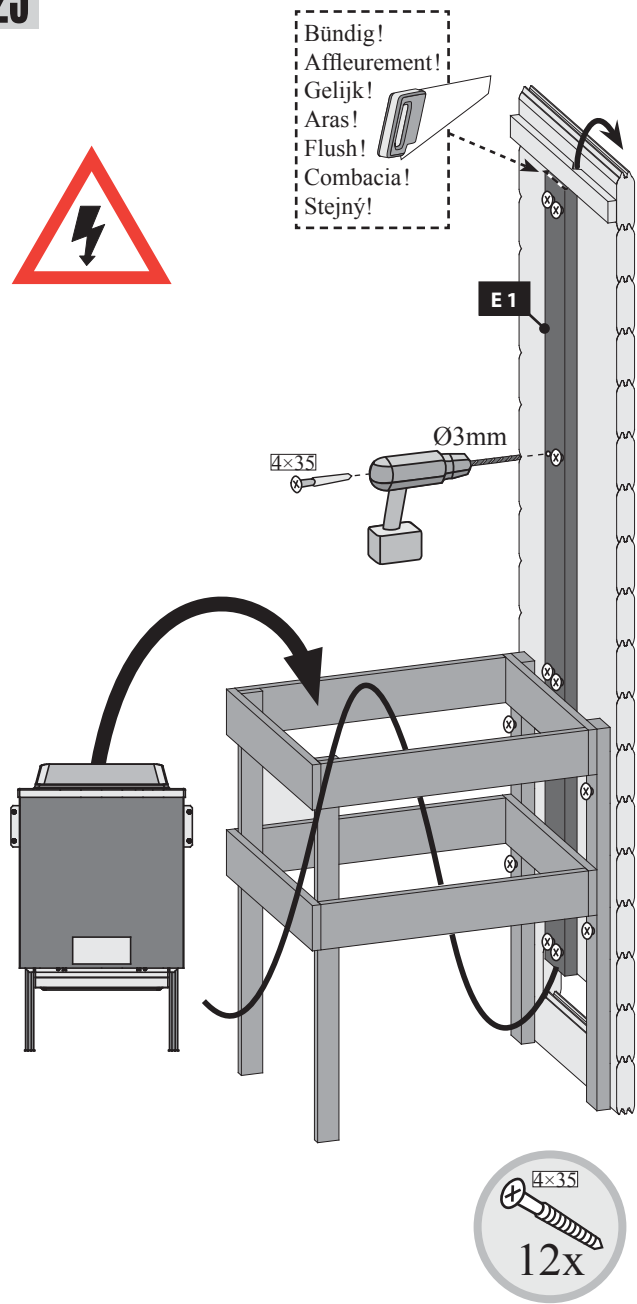

- Einbau Saunatür
- Sauna deur installatie
- Sauna Instalace dveře
- Sauna door installation
- Instalación de la puerta Sauna
- Installation de porte Sauna
- Installazione porta Sauna

!!! 04 → ... !!!



 Installation TÜV-Schild

 Installatie TÜV Shield

 Instalace TÜV Shield

 Installation TÜV Shield

 Installazione TÜV Shield

 Namestitev TÜV tablice

 Installation TÜV Shield

 Instalación TÜV Escudo

01

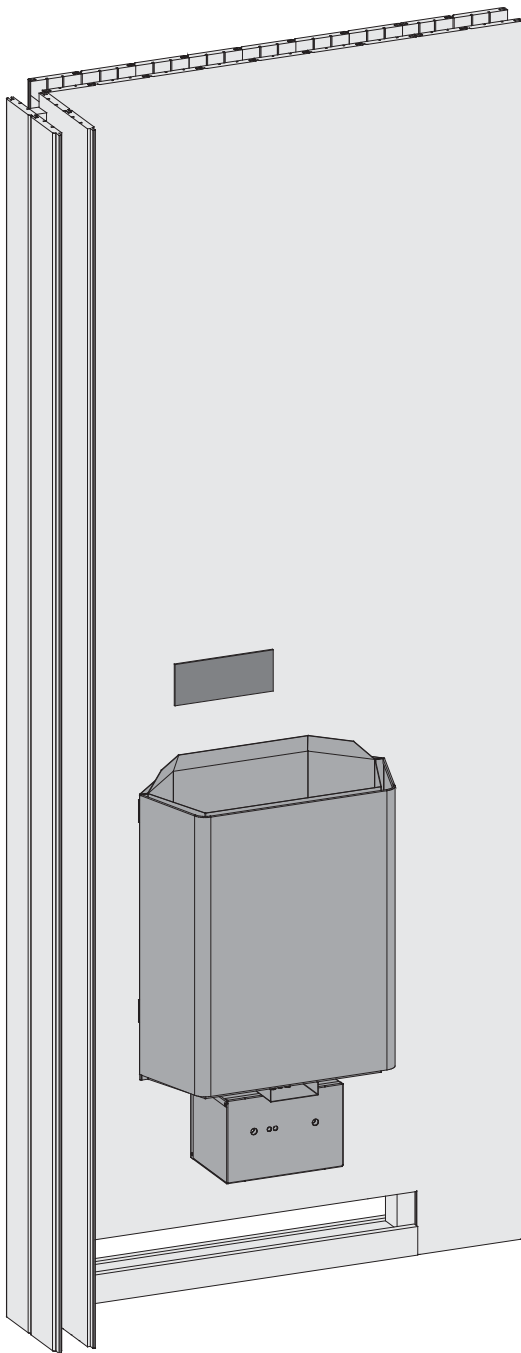



 Entfernen Sie die Schutzfolie vom beiliegenden TÜV-Schild. Lassen Sie den Saunaofen von einem zugelassenen Elektrofachmann anschließen. Dieser markiert den installierten Ofen auf dem TÜV-Schild. Bringen Sie das TÜV-Schild an einer gut sichtbaren Stelle über dem Ofen an.

 Remove the protective film from the accompanying Participate Schild. Lassen connecting the heater by a licensed electrician. This marks the installed furnace on the TÜV sign. Attach the TÜV sign at a conspicuous place on the stove.

 Retirez le film protecteur de l'accompagnant Participer Schild. Lassen raccorder l'appareil par un électricien agréé. Ceci marque le four installé sur le signe TÜV. Fixer le signe de TÜV à un endroit bien en vue sur le poêle.

 Verwijder de beschermfolie van de begeleidende Deelnemen Schild. Lassen het aansluiten van de kachel, door een erkende elektricien. Dit markeert de geïnstalleerde oven op het TÜV teken. Bevestig de TÜV teken op een opvallende plaats op het fornuis.

 Rimuovere la pellicola protettiva dal accompagna Partecipa Schild. Lassen collegando il riscaldatore da un elettricista qualificato. Questo segna il forno installato sul segno TÜV. Fissare il segno TÜV in un luogo ben visibile sulla stufa.

 Retire la película protectora de la Schild. Lassen acompaña Participar conectar el calentador por un electricista autorizado. Esto marca el horno instalado en el signo TÜV. Coloque el cartel de TÜV en un lugar visible en la estufa.

02

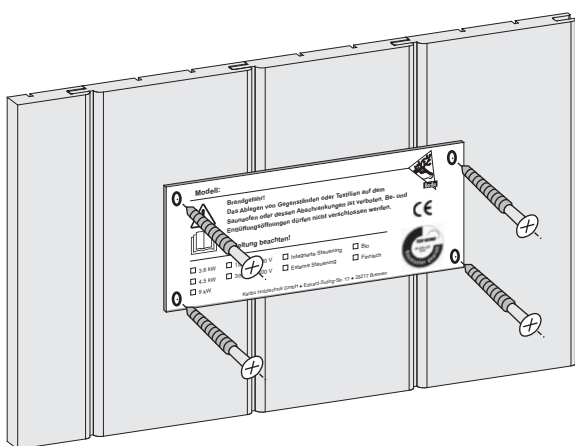

 Odstraňte ochrannou fólii z doprovodného Hlavní Schild. Lassen připojení ohříváče licencovaným elektrikář. Toto označí Instalovaný pec na znamení TÜV. Připevněte znamení TÜV na dobře viditelném místě na sporáku.

 S priložene tablice odstranite zaščitno folijo. Peč savne naj priključi usposobljeno osebnje, ki inštalirano peč označi na TÜV tablici. Tablico namestite na vidno mesto peči.

